

DRAWING MADE IN AMERICAN PROJECTION

© 1954 BY AMP INCORPORATED. ALL RIGHTS RESERVED. AMP PRODUCTS COVERED BY PATENTS AND/OR PATENTS PENDING.

REVISIONS				
ZONE	LTR	DESCRIPTION	DATE	APPROVED
	C	REDRAWN, REV # ADDED TAPE NOS P-6080	5-13-70	<i>Jme</i>
	D	INACTIVE ECN P-6740	2-21-72	<i>BB</i>
	E	2--3 INACTIVE PER P-9260	dc 11/10/82	<i>Jpa</i>
	F	OBS. 2--3 REV. G-2591	BT 10-19-87	<i>PMF</i>
	G	REV PER G-4732	JT 7/27/88	<i>RJR</i>
	H	REV./ 0720-0036-93	TQ 3-5-93	<i>ML</i>
	J	REV/0620-0273-97	TM 1-12-98	<i>ML</i>

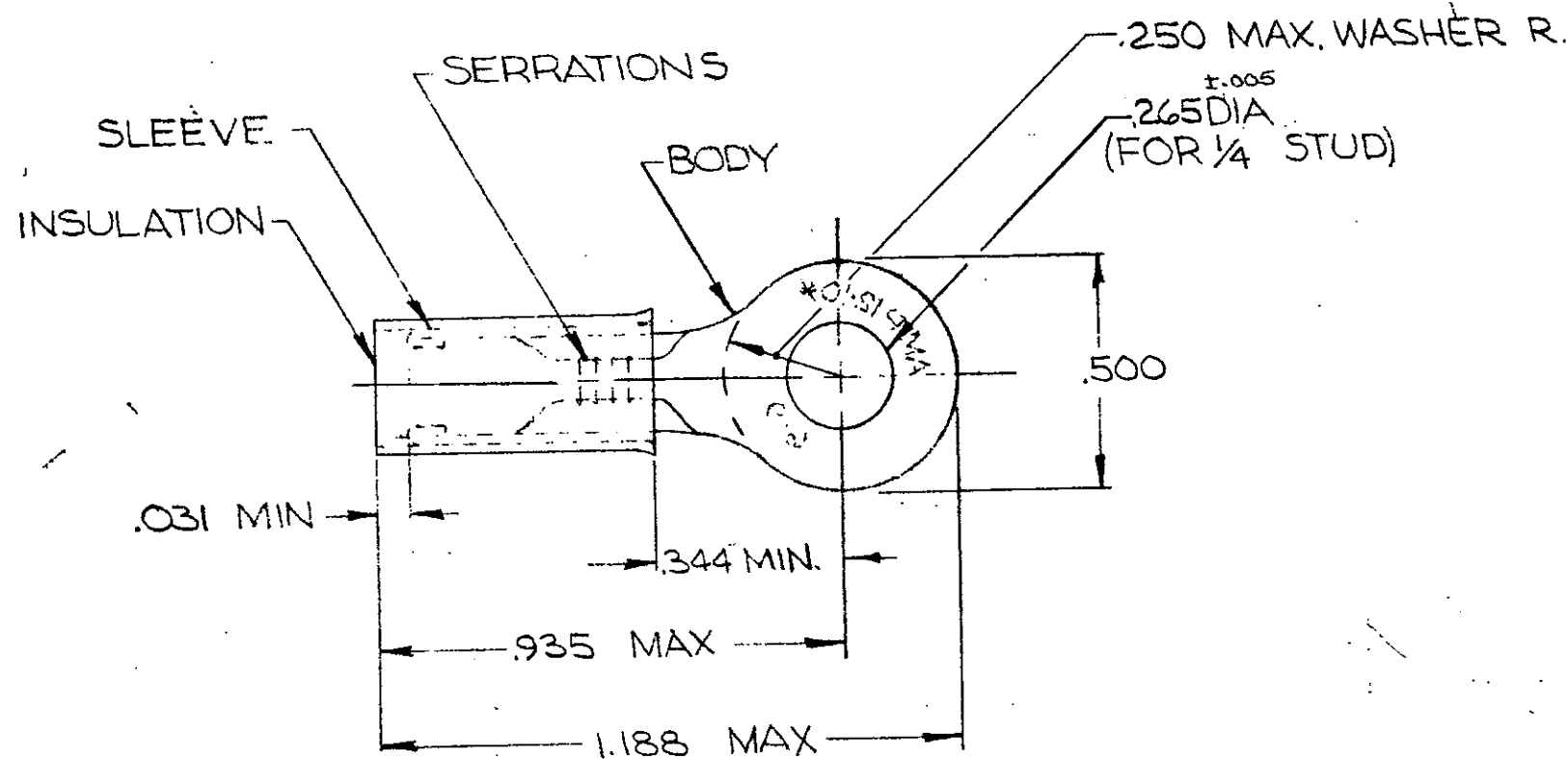

FOR .150 TO .230 INSULATION DIA.
TONGUE MATERIAL THK = .040 ±.002

OBSOLETE
INACTIVE Ⓣ

QTY	DESCRIPTION	PART NO.	MATERIAL & FINISH
50	LOOSE PC. BOX	8-35273-2	INSULATION, SLEEVE, AND BODY: SAME AS 35273
1	2-35273-1 ON TAPE	2-35273-3	INSULATION: GREEN PVC SLEEVE: COPPER (ASTM B152)
1	WIRE TERMINAL	2-35273-1	BODY: COPPER (ASTM B152) TIN PL (ASTM B545)
1	35273 ON TAPE	2-35273-2	INSULATION: YELLOW NYLON SLEEVE: COPPER (ASTM B152)
1	WIRE TERMINAL	35273	BODY: COPPER (ASTM B152) TIN PL (ASTM B545)

UNLESS OTHERWISE SPECIFIED DIMENSIONS ARE IN INCHES. TOLERANCES ON: DECIMALS ±.008 ANGLES ±5°	CONTRACT NO.		AMP AMP INCORPORATED HARRISBURG, PENNSYLVANIA	
	DR	4-23-70		
	CHK	<i>Wayne Mullins</i> 5-13-70		
	APPD	<i>M. Ensign</i> 5-13-70		
MATERIAL	REL	<i>W. White</i> 5-13-70	NAME	WIRE TERMINAL P.I.D.G.-RING TONGUE WIRE SIZE: 12-10
	DSGN APPD	<i>A. Young</i> 5-18-70	SIZE	B
	OTHER APPD		CODE IDENT NO.	00779
SEE TABLE			NUMBER	35273
			SCALE	NTS.
				SHEET 1 OF 1

CUSTOMER DRAWING